

Function

Ball valve full bore, coated steel lever, F/F thread, double o-ring anti-explosion control stem.

Suitable for water in heating/cooling systems.

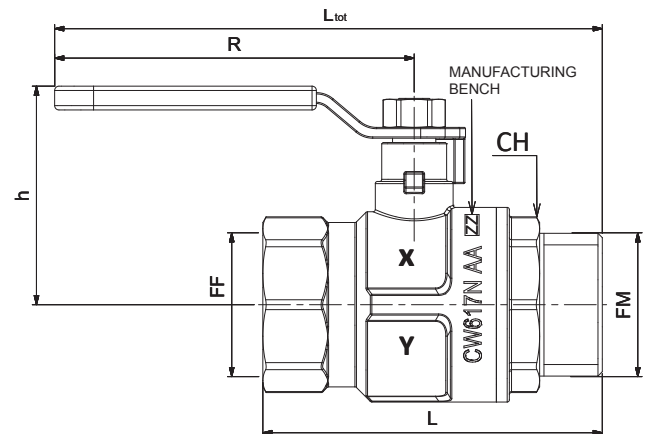
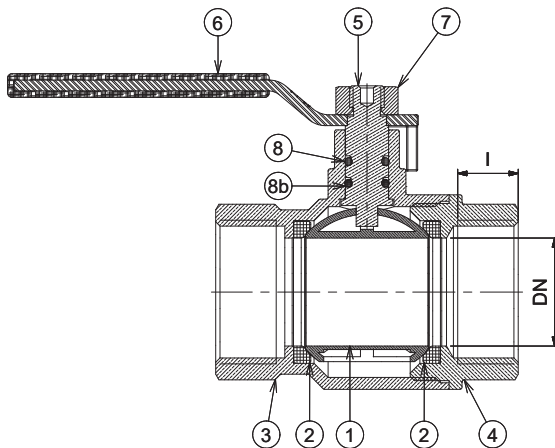
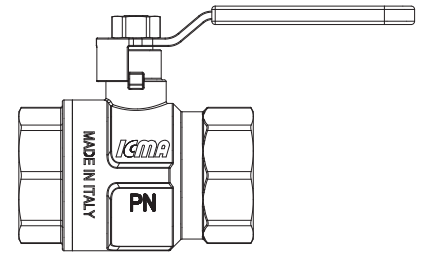

P.N.	DESCRIPTION	MATERIAL
1	BALL	CW617N - UNI EN 12165 - CHROME PLATED
2	SEAT GASKET	PTFE
3	BODY	CW617N - UNI EN 12165
4	SLEEVE	CW617N - UNI EN 12165
5	COMMAND ROD	CW617N - UNI EN 12164
6	LEVER	STEEL DD11 - PVC
7	NUT	ZINC PLATED STEEL
8	O-RING	NBR
8b	O-RING	FKM

Dimensions

CODE	X		Y	ISO 228/1		L	I	R	CH	h	Ltot
	SIZE	PN (bar)		DN	F1						
87353ADXX	1/2"	50	15	1/2"	1/2"	51	11	83	25	41,5	108,5
87353AEXX	3/4"	40	20	3/4"	3/4"	58	12	83	31	45	112
87353AFXX	1"	40	25	1"	1"	70	14	83	38	50,5	118
87353AGXX	1"1/4	30	32	1"1/4	1"1/4	85	18	141,5	47	66,5	184
87353AHXX	1"1/2	30	40	1"1/2	1"1/2	94	18	141,5	54	73	188,5
87353AJXX	2"	25	50	2"	2"	110	20	141,5	66	80	196,5

Different lever coating color available:

- **BLUE:** insert '12' instead of 'XX' in the code ending;
- **RED:** insert '18' instead of 'XX' in the code ending;
- **BLACK:** insert '34' instead of 'XX' in the code ending;

Field of use

Min. working temperature: -20°C with 50% glycol solutions
 Max working temperature: 150°C
 Max operating pressure at 20°C

	1/2"	3/4"	1"	1"1/4	1"1/2	2"
bar	50	40	40	30	30	25
psi	725	580	580	435	435	362,5

Head loss at 20°C

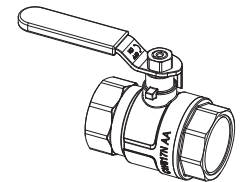
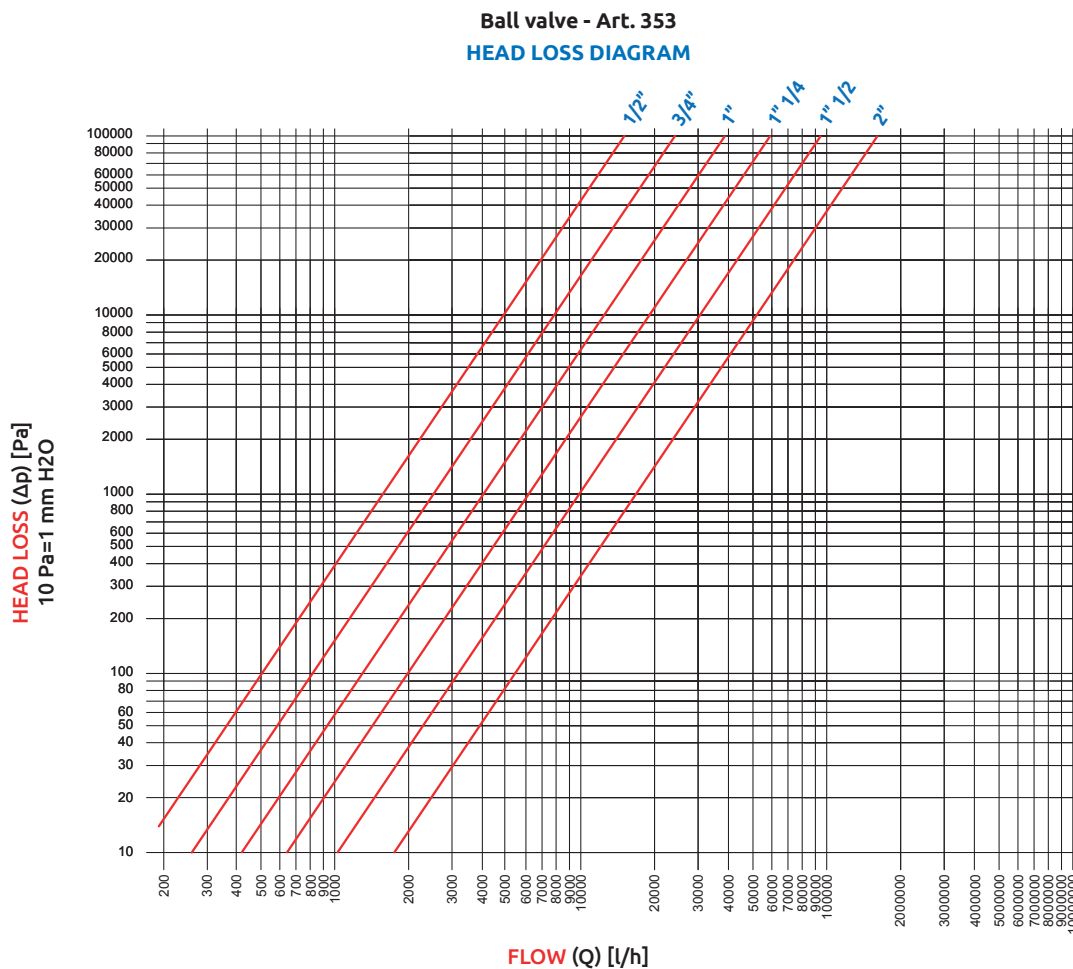

Size	Kv [m ³ /h]
1/2"	15,5
3/4"	26,2
1"	41,4
1"1/4	63,6
1"1/2	101,2
2"	169,5